

## Hedgehog House Instruction Manual



After Sales Support

Call 0871 911 7031

Email

[customerservice@gardengearonline.co.uk](mailto:customerservice@gardengearonline.co.uk)



Product Code G2579

Thank you for purchasing this product, which has been made to demanding high quality standards and is guaranteed for domestic use against manufacturing faults for a period of 12 months from date of

**For correct usage, please read these instructions carefully before use and keep in a safe place for future reference.**

Before starting assembly, make sure that all parts are present.

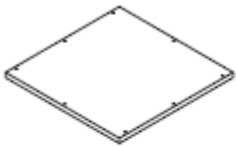
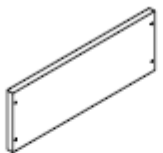
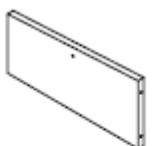
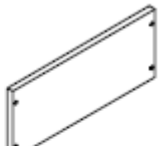
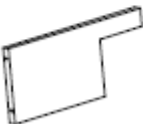
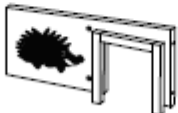
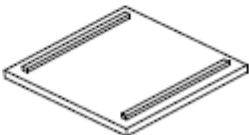
### Parts list

<p><b>A</b></p>  <p><b>X1</b></p>	<p><b>B</b></p>  <p><b>X1</b></p>	<p><b>C</b></p>  <p><b>X1</b></p>	<p><b>D</b></p>  <p><b>X1</b></p>
<p><b>E</b></p>  <p><b>X1</b></p>	<p><b>F</b></p>  <p><b>X1</b></p>	<p><b>G</b></p>  <p><b>X1</b></p>	<p><b>H</b></p>  <p><b>X19</b></p>

### Assembly

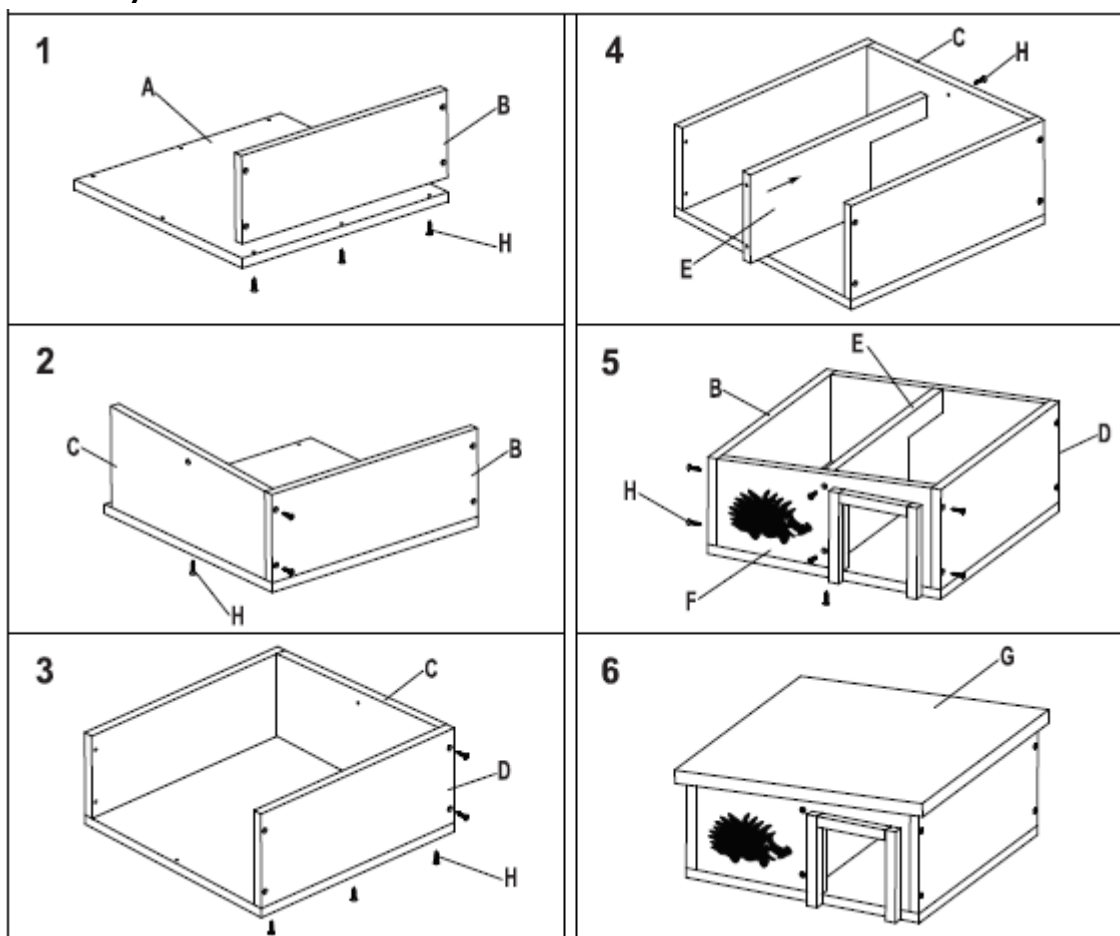

**Treatment**

The hedgehog house comes already pre-treated on the outside. Periodically, the wood will need to be treated with water-based preservative, but only on the outside. On no account should the hedgehog house be creosoted or treated with non-water-based preservatives or paint as the fumes remain for a long time and can be very harmful.

Please note that due to the natural properties of timber, parts may swell when subjected to changes to temperature and humidity (i.e. moving the hedgehog house from outdoors to indoors or changes in seasons).

## GUARANTEE

### IMPORTANT

**Please do not return this product without first calling the Customer Service number below:  
0871 911 7031\***

Thank you for purchasing this product, which has been made to demanding high quality standards and is guaranteed for domestic use against manufacturing faults for a period of 12 months from the date of purchase.

Register your product for an extended 2-year warranty by visiting our website [www.gardengearonline.co.uk](http://www.gardengearonline.co.uk). The product must be registered, along with your contact information, within 30 days of purchase. For full terms and conditions please visit our website.

This guarantee does not affect your statutory rights. If your product fails due to a defect in material or workmanship during this period, please return it to the place of purchase. Normal wear and tear is not covered under the guarantee.

Any guarantee is invalid if the product has been misused or subject to neglect or an attempted repair other than by our own service centre.

Due to continuous product improvement, we reserve the right to change the product specification without prior notice.

#### **After Sales Customer Service:**

Customer Service Department, Branded Garden Products Ltd, Premier House, Hortonwood 7, Telford, TF1 7GP, UK

Telephone: 0871 911 7031\*

E-mail [customerservice@gardengearonline.co.uk](mailto:customerservice@gardengearonline.co.uk)

Please retain for future reference.

Colours and contents may vary.

\*Calls cost 13p per minute, plus your phone company's access charge